

ACCESS 2/3 SG -WAY KIT MANUAL

User Manual

Français page 8

Congratulations on choosing Focal automobile speakers.

Focal speakers remain high quality products, due to the multitude of advanced materials used. Detailed research and development in the laboratory, from dedicated engineers and technicians, played a major role in producing such high performing products. To gain the best results from your speakers, please ensure you follow these recommendations. If not followed correctly any fault observed, may not be covered by the guarantee.

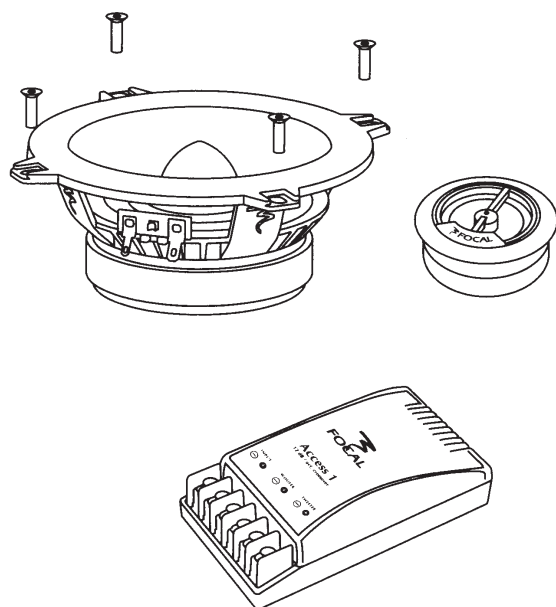

Technical advances, included in the Access range

- Polypropylene cones
- TN44 aluminum / magnesium inverted dome tweeter
- Separated crossover, fully optimised with adjustable level control. High quality components used throughout.
- Butyl surround

Included

- 2 x woofer / midrange (2-way kits)
- 2 midrange (3-way kits)
- 2 woofer (3-way kits)
- 2 x tweeters
- 2 x gaskets
- 2 x crossovers
- fixing screws
- 2 x lock washers



Focal-JMlab® - BP 374 - 108, rue de l'Avenir - 42353 La Talaudière cedex - France - www.focal.com
Tél. (+33) 04 77 435 700 - Fax (+33) 04 77 376 587

Due to constant technological advances, Focal reserves its right to modify specifications without notice. Images may not conform exactly to specific product.

ACCESS 2/3 SG -WAY KIT MANUAL

User Manual

2

Important recommendations

Before attempting any installation work, it is very important to verify how much space is available to fit the speakers into the vehicle.

Key points:

- For direct replacement of original speakers, please check there is enough space for your new Focal speakers.
- Ensure the speaker is clean from debris and metallic particles that maybe attached (especially after drilling)
- Do not touch the tweeter cone.

Choice of installation and positioning the tweeter

To achieve best results for your installation, please follow these simple guidelines

- Use a variety of speakers to achieve a large bandwidth, the most central possible.
- Speakers positioned in the most forward location possible, for correct staging.
- Tweeters positioned preferably high in the doors or in the dash (if space permitting), to obtain un-muddled high and midrange frequencies. These being directive to the listener.
- To position the tweeters direct in-line to the listeners ears, for improved imaging.

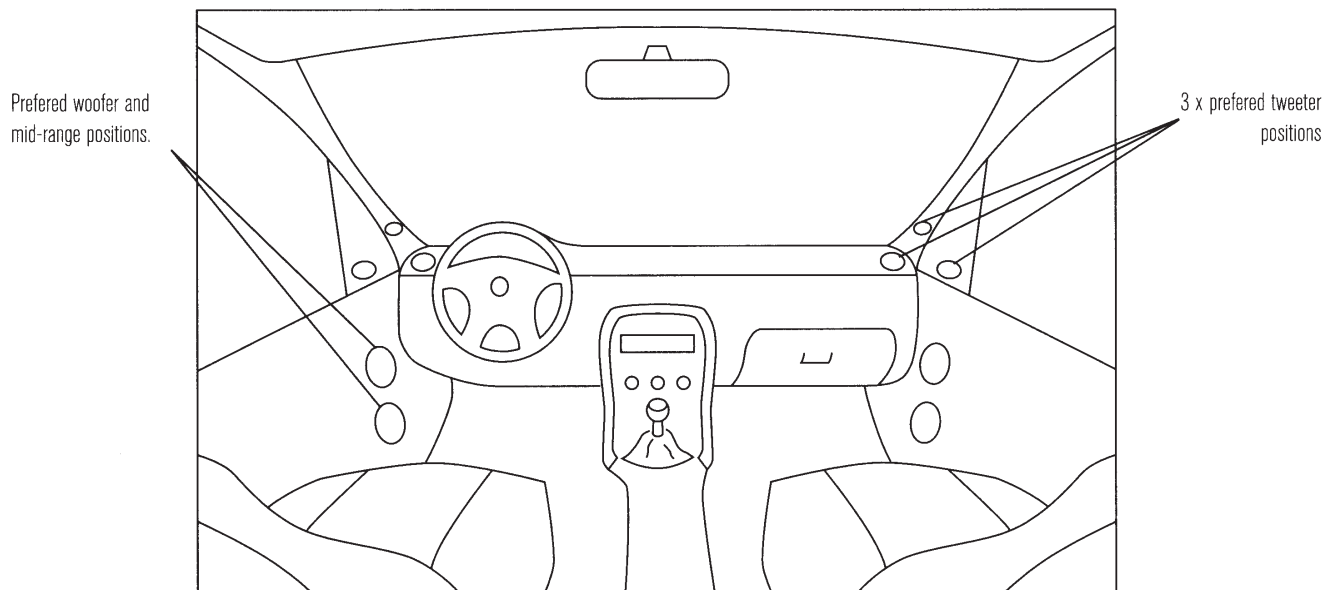

ACCESS 2/3 SG -WAY KIT MANUAL

User Manual

3

Cables and connections

- For best results with your Access speakers, we recommend you include the use of Focal cables.
- Alternatively, other high quality cable can be used, if sufficient section thickness is available (minimum thickness = 1mm²). This is particularly important for long lengths of cable to ensure a strong efficient signal is maintained.
- Always ensure the polarity is respected, (+ is connected to +) and (- is connected to -).
- Maintain correct connections, from principal source radio/amplifier (left/right/front and rear), and crossover to speakers (tweeter to tweeter), (mid to mid), (woofer to woofer), is always observed.
- If the woofer is located at the bottom on the door, connect the woofer directly on the amplifier in order to have more dynamic midrange.

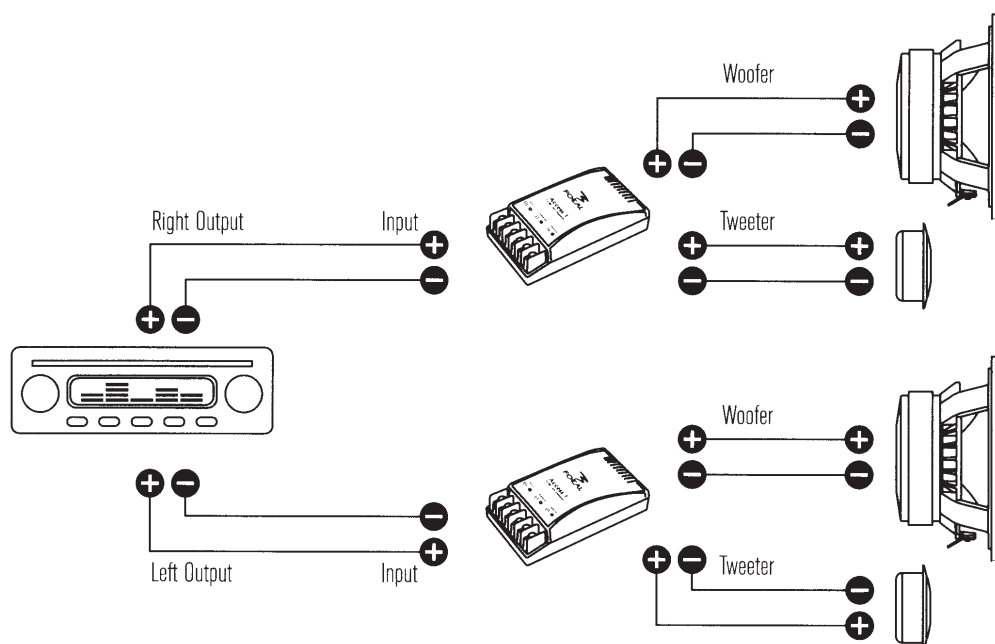

Fitting the tweeter

There are two mounting possibilities available: surface or flush mount. To easily install the tweeter, you have to turn the pod round, then release the tweeter.

Surface mounting (dashboard): choose the angle that best suits your installation (10° or 30°) and mount the pod firmly using the screws supplied. Feed the wire through the hole in the pod and re-fit the tweeter in place.

Flush mounting: cut a neat 45mm diameter hole in the panel where you want to place the tweeter. Then, insert the tweeter in the front panel. In the same time, put the lock washer in the rear panel. Feed the wire through the hole in the pod and push simultaneously on the pod and the washer to lock the pod on the panel. Feed the wire through the hole in the pod and re-fit the tweeter in place.

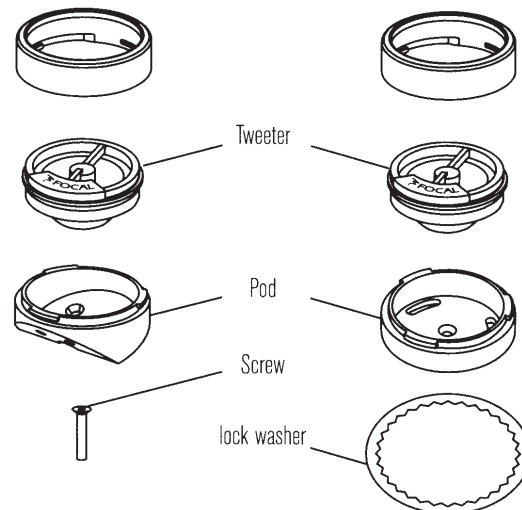

ACCESS 2/3 SG -WAY KIT MANUAL

User Manual

3-way kits connections

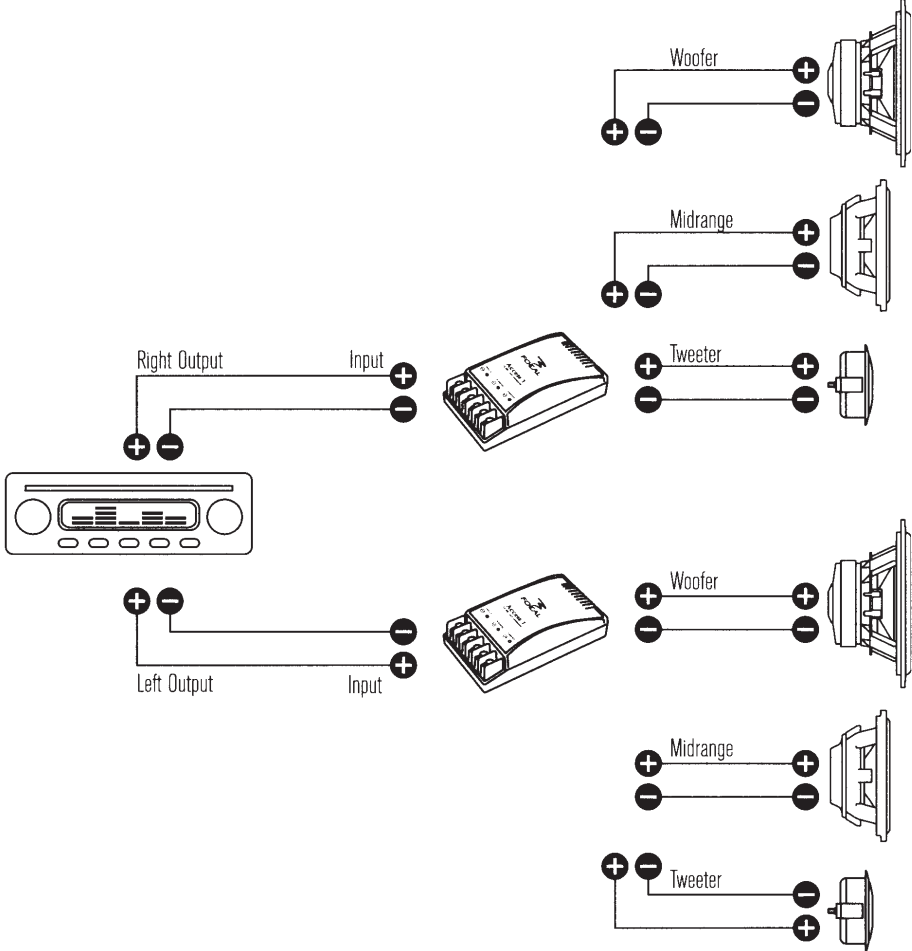

ACCESS 2/3 SG -WAY KIT MANUAL

User Manual

5

Fitting the crossover

Locate the crossovers in a dry, preferably ventilated area, using either the screws supplied or double-sided tape.

To open the box, squeeze the middle on the side, and remove the cover.

In some cases, depending on your installation and the space available, it maybe easier to route the cables and connect to the crossover, before securing the crossover to the vehicle. Please check before.

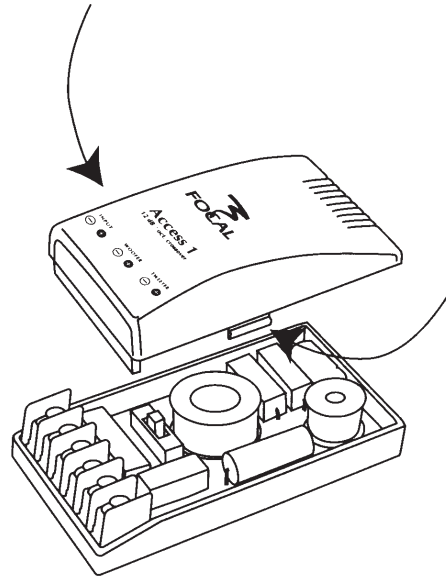

Level adjustment of tweeter and midrange

The toggle switch found inside the crossover, allows the user to adjust the tweeter level.

This user-friendly option allows effective adjustments to be made, to your own personal listening pleasure, plus optimising the infinite amount of speaker installation locations available.

This allows the system to be "tailor made" to your vehicle, effectively ensuring the best acoustics are possible. Remember too much treble and your system may sound aggressive, thus suffer a lose of dynamics, resulting in poor definition.

Level position 0 or -3dB, if the tweeter is located very close to woofer-midrange, or in kick panel, for the 2-way kits, or +3, 0dB for the 3-way kits.

Level position -3 or -6dB, if the tweeter is located high in the vehicle (in the dash or high in the doors) with the woofer positioned comparatively low for the 2-way kits and 0, -3dB for the 3-way kits.

Tweeter level adjustment
-6dB, -3dB and 0dB

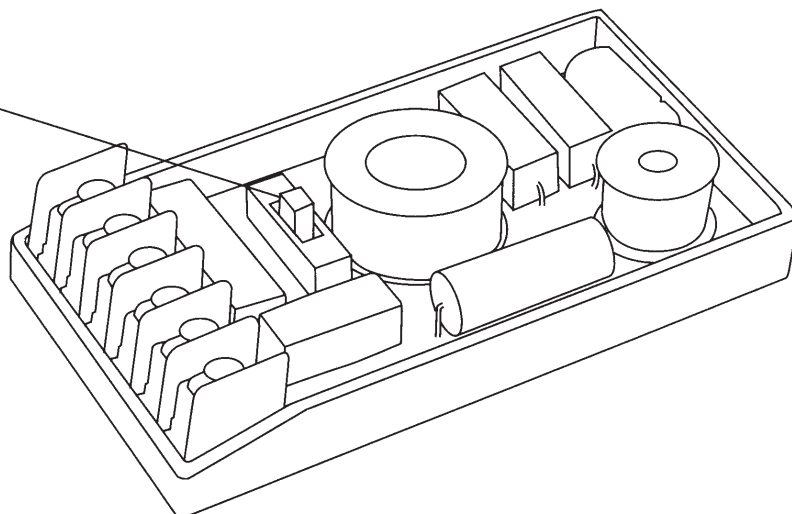

ACCESS 2/3 SG -WAY KIT MANUAL

User Manual

Specifications

	130 A1 SG	165 A1 SG	165 A3 SG
Type	2-way kit	2-way kit	3-way kit
Diameter	5.12" (130mm)	6.5" (165mm)	4" (100mm) 6.5 (165mm)
Maximum power	100W	120W	160W
Nominal power	50W	60W	80W
Sensitivity (2.8V/1m)	91dB	92dB	90dB
Frequency response	65Hz – 20kHz	60Hz – 20kHz	55Hz – 20kHz
Impedance	4 ohms	4 ohms	4 ohms
Fitting diameter	4.61" (117mm)	5.35" (141mm)	3.70" (94mm) 5.55" (141mm)
Mounting depth	2.20" (56mm)	2.60" (66mm)	2.17" (55mm) 2.60" (66mm)

How can you improve the sound quality of your speakers?

Easy. To improve the sound quality of your speakers notably those installed into the doors, Focal has the answer. Known as "BAM", this material acts as a sound absorber, to effectively reduce unwanted resonances and ensure your speakers produce a more full sound. No-fuss installation ensures this accessory, proves to be a real asset for your Focal speakers/installation. Consult your Focal retailer for further information.

ACCESS 2/3 SG -WAY KIT MANUAL

User Manual

7

What is the power for your amplifier?

Access speakers are already highly efficient, with improved sensitivity. Therefore, their use with a high power head unit will provide comfortable listening pleasure.

However used in a more high-end system, with separate amplification, the audio quality will be greatly improved. It is very important to know the rated power of the amplifier is suitable for the speakers used. Otherwise your speakers may distort, or possible damage could occur.

Always consult the owners manual of the principal source (head unit/amplifier), to ensure the power rating is compatible. A safe guide is to ensure the maximum power of the amplifier is not greater than the nominal power of the speakers.

Installation upgrade (with the help of a subwoofer)

If you want your system to have bass, with real punch and power, we recommend the inclusion of a subwoofer. This will greatly improve your listening pleasure and give your system, some real physical dimension.

Focal has therefore developed a range of subwoofer drivers and complete subwoofer systems, to compliment your Access speakers.

Consult your local dealer, or check out these exciting products on the Focal Internet site: www.focal.com

Guarantee

All Focal loudspeakers are covered by guarantee drawn up by the official Focal distributor in your country.

Your distributor can provide all details concerning the conditions of guarantee. Guarantee cover extends at least to that granted by the legal guarantee in force in the country where the original purchase invoice was issued.

In addition to Car hi-fi systems, Focal offers personalized solutions for the equipment of your house. Enjoy at home the hi-fi and home cinema sensations provided by the Focal sound. Four product lines by the French leading loud-speaker manufacturer, are at your disposal to share with you our passion : the Spirit of Sound / www.focal-fr.com



Your Focal-JMLab product was developed and manufactured with high-quality materials and components which can be recycled and/or re-used. This symbol indicates that electrical and electronic equipment must be disposed of separately from normal garbage at the end of its operational lifetime. Please dispose of this product by bringing it to your local collection point or recycling centre for such equipment. This will help to protect the environment in which we all live.

For the validation of the Focal guarantee, send back this sheet within 10 days to the following address:

Focal- JMLab - BP 374 - 108, rue de l'Avenir - 42353 La Talaudière cedex - FRANCE

About yourself:

Your name: _____ Your age: _____ Your job: _____

Your full address: _____

Your e-mail address: _____

Your hobbies:

At home, do you own Hi-Fi loudspeakers? - Yes - No

If yes, specify the brand: _____

Do you read the press? - Yes - No

If yes, which magazine(s)? _____

Your audio/video equipment (brands and models) before the acquisition of Focal products:

CD player/tuner: _____ Multimedia player: _____

Navigation system: _____ Amplifier: _____

Speakers: _____ Enclosure/subwoofer: _____

Other elements: _____

Your choice for the purchase of this Focal model was made according to:

- | | |
|---|--|
| <input type="checkbox"/> - Dealer's advice | <input type="checkbox"/> - Friend's or family's advice |
| <input type="checkbox"/> - Visiting an exhibition/a show | <input type="checkbox"/> - Quality-price ratio |
| <input type="checkbox"/> - Sound quality/listening room | <input type="checkbox"/> - Already own Focal products |
| <input type="checkbox"/> - Reliability/manufacturing quality | <input type="checkbox"/> - Catalogues |
| <input type="checkbox"/> - Design/Finish | <input type="checkbox"/> - French product |
| <input type="checkbox"/> - Article in the press (if yes, specify the title of the magazine) _____ | <input type="checkbox"/> - Other : _____ |

Your Focal product:

Model: _____ Serial number: _____

Dealer's name: _____ City: _____

Date of your purchase: _____ Price of your purchase: _____

Did you leave the product installation to your dealer's care? - Yes - No

If not, why? _____

Now it's possible to register on line : www.focal.com/warranty

This information is necessary to our company to deal with your request. It is registered in our customer file and can give you the right to have access to and correct the information that concerns you through our customer service (+33 477 435 700).

If you do not wish to have your data used by our partners on commercial purpose, tick this box.

If you do not wish to receive commercial propositions from our partners by e-mail, please tick this box.

You may receive commercial offers from our company for products similar to those you have bought.

If you do not wish to, tick that box.

The information given on this page will remain confidential.

SCCP-111117/1 - CODO 1333